

# 1 PC 316SS REDUCED PORT BALL VALVE

## MODEL LVSS1BV



### FEATURES:

- **Threaded:** NPT
- **Materials:** SS316
- Working pressure 800/1000 PSI for WOG (See chart below for sizes)
- Adjustable stem packing
- Pure Teflon™ seals and seats
- Temperature range: -60 to 450°F
- Blow-out proof stem and safe pressure-reducing hole
- 100% leakage tested at 100 PSI air under water
- Hydrostatic test pressure 1500 PSI
- **Size:** 1/4"- 4" reduced port/bore (800 PSI/1000 PSI)

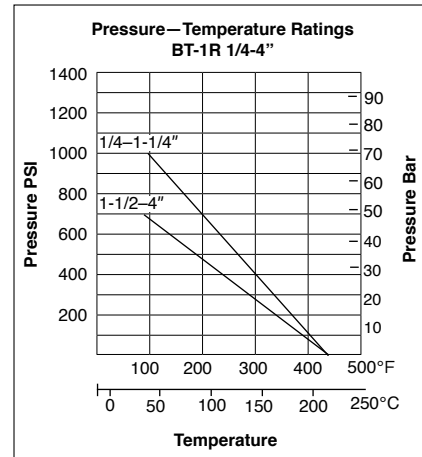
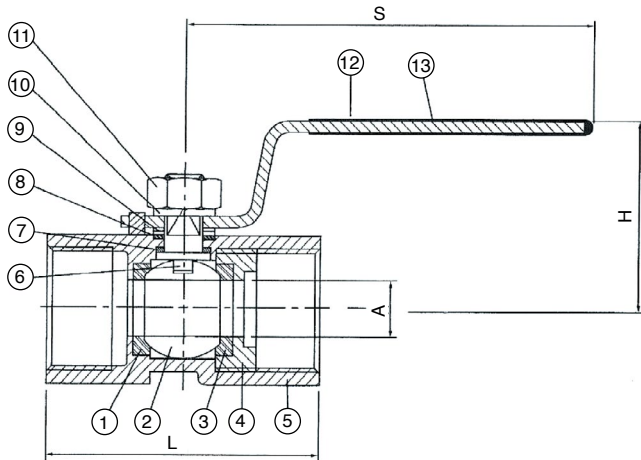

No.	NAME	MATERIAL	QTY
1	Seat	PTFE	2
2	Ball	316/304	1
3	Joint Gasket	PTFE	1
4	Body Insert	CF8M	1
5	Body	CF8M	1
6	Stem	316	1
7	Thrust Washer	PTFE	1
8	Stem Packing	PTFE	1
9	Gland Nut	304	1
10	Stem Washer	304	1
11	Stem Nut	304	1
12	Plastic Sleeve	PVC	1
13	Handle	SS 304	1

Size (In.)	S	H±1	A	L±0.5
1/4	59	28.5	4.6	39.0
3/8	79	33.5	7.0	44.0
1/2	87	38.0	9.0	56.5
3/4	85	41.5	12.5	58.5
1	99	46.0	16.0	71.0
1-1/4	99	51.5	20.0	78.0
1-1/2	126	65.5	25.0	83.0
2	126	71.5	32.0	100.0
2-1/2	176	87.5	38.0	122.0
3	176	95.0	50.0	142.0
4	—	—	—	—

PROJECT		APPROVAL STAMP	
PROJECT:		<input type="checkbox"/>	APPROVED
ADDRESS:		<input type="checkbox"/>	APPROVED AS NOTED
ENGINEER:		<input type="checkbox"/>	NOT APPROVED
SUBMITTAL DATA:		REMARKS:	
NOTES 1:			
NOTES 2:			