

2 PC 316SS FULL PORT BALL VALVE

MODEL LVSS2BV



FEATURES:

- **Threaded:** NPT
- **Materials:** SS316
- Working pressure 1000 PSI for WOG
- Adjustable stem packing
- Pure Teflon™ seals and seats
- Temperature range: -60 to 450°F
- Blow-out proof stem and safe pressure-reducing hole
- 100% leakage tested at 100 PSI air under water
- Hydrostatic test pressure 1500 PSI
- **Size:** 1/4" - 4" full port/bore (1000) PSI

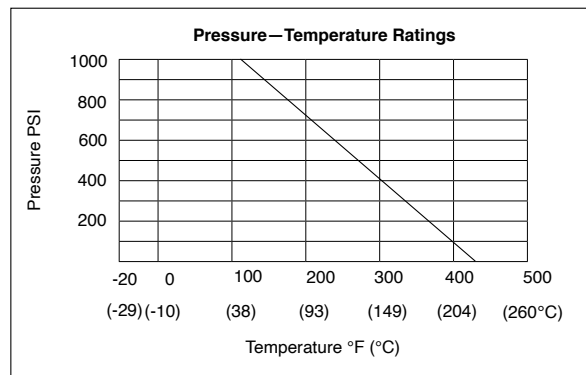
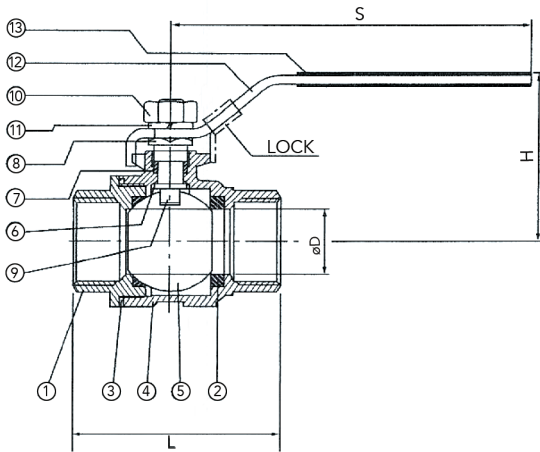

No.	NAME	MATERIAL	QTY
1	Cap	316	1
2	Ball Seat	PTFE	2
3	Joint Gasket	PTFE	1
4	Body	316	1
5	Ball	316	1
6	Thrust Washer	PTFE	1
7	Stem Packing	PTFE	1
8	Gland Nut	304	1
9	Stem	316	1
10	Stem Nut	304	1
11	Spring Washer	304	1
12	Handle	304	1
13	Plastic Sleeve	PVC	1

Size (In.)	D	L	H	S
1/4	12.7	47.3	46.6	99.5
3/8	12.7	47.3	46.6	99.5
1/2	15.0	58.2	48.2	99.5
3/4	20.0	65.5	61.7	126.5
1	25.0	76.5	69.3	126.5
1-1/4	32.0	90.0	80.7	153.0
1-1/2	38.0	98.3	87.2	153.0
2	50.8	121.7	95.4	192.0
2-1/2	65.0	145.2	119.5	248.0
3	76.0	167.0	130.0	248.0
4	100.0	224.0	167.2	320.0

PROJECT	APPROVAL STAMP
PROJECT:	<input type="checkbox"/> APPROVED
ADDRESS:	<input type="checkbox"/> APPROVED AS NOTED
ENGINEER:	<input type="checkbox"/> NOT APPROVED
SUBMITTAL DATA:	REMARKS:
NOTES 1:	
NOTES 2:	