



# ANGLE TEST & DRAIN WITH ADJUSTABLE PRV & GAUGE

MODEL LVATD-RT



**FEATURES:**



- UL Listed and FM Approved
- Size range: 3/4", 1", 1-1/4", 1-1/2", 2"
- Orifice options: 2.8K, 4.2K, 5.6K, 8.0K, 11.2K, 25.2K
- 175 - 310 PSI field adjustable PRV
- 300 PSI stainless steel gauge
- 3-Way globe valve
- Tamper-resistant test orifice and sight glass
- Horizontal or vertical installation
- NPT connections conform to ASME B1.20.01
- Manufactured in accordance to NFPA13, 13R, 13D
- Test and drain with optional PRV, available nominal K-Factor: 2.8, 4.2, 5.6, 8.0, 11.2, 14.0 (available on 1-1/4" - 2" size units only), and 25.2 (available on 1-1/2" and 2" size units only)

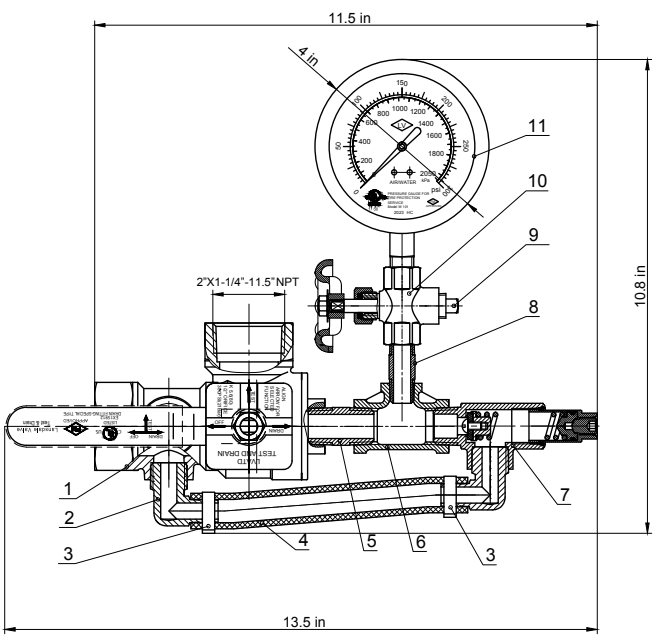

| MATERIAL SPECIFICATIONS |  |
|-------------------------|--|
| ITEM                    | DESCRIPTION                                |
| 1                       | Test & Drain - MODEL LVATD                 |
| 2                       | Hose Fittings                              |
| 3                       | Hose Clamps                                |
| 4                       | Hose                                       |
| 5                       | 1/2" x 1-1/2" Black Nipple 1/2" x 1-1/2"   |
| 6                       | 1/2" x 1/4" x 1/2" Malleable Iron Tee      |
| 7                       | 1/2" 175 PSI - 310PSI Field Adjustable PRV |
| 8                       | 1/4" x 1-1/2" Black Nipple 1/4" x 1-1/2"   |
| 9                       | 1/4" Malleable Iron Plug 1/4"              |
| 10                      | 1/4" - 3 Way Valve                         |
| 11                      | Air/Water Gauge- 300PSI                    |

| PROJECT         | APPROVAL STAMP                             |
|-----------------|--|
| PROJECT:        | <input type="checkbox"/> APPROVED          |
| ADDRESS:        | <input type="checkbox"/> APPROVED AS NOTED |
| ENGINEER:       | <input type="checkbox"/> NOT APPROVED      |
| SUBMITTAL DATA: | REMARKS:                                   |
| NOTES 1:        |  |
| NOTES 2:        |  |