

ANGLE VALVE - SOFT DISC

MODEL LVAV

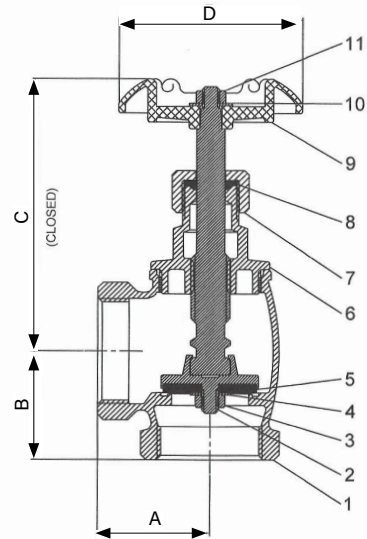

File EX28700



SIZE	A	B	C	D
1/2"	1.08	.93	2.72	2.17
3/4"	1.25	1.32	3.23	2.29
1"	1.54	1.42	3.70	2.56
1-1/4"	1.76	1.68	4.0	3.0
1-1/2"	2.0	1.93	4.88	3.27
2"	2.36	2.34	5.83	4.0

MATERIAL LIST			
NUMBER	DESCRIPTION	MATERIAL	SPEC ASTM
1	Body	Cast Brass	B584 C857000
2	Disc Holder	Brass Rod Forged Brass	B16 C36000 (1/2"- 1 1/2") B124 C37700 (2" Only)
3	Seat Nut	Brass Rod Stainless Steel	B111 C28000 (1/2"-3/4") SS.304 (1"-2")
4	Washer	Stainless Steel	S.S.304 (1"-2")
5	Seat	NBR	
6	Bonnet	Cast Brass	B584 C85700
7	Packing Nut	Brass Rod	B16C36000
8	Packing	Teflon	PTFE
9	Handwheel	Cast Iron	A48Clas No. 30
10	Name Plate	Aluminum	Commercial
11	Handwheel	Steel	A29. GR1010

PROJECT	APPROVAL STAMP
PROJECT:	<input type="checkbox"/> APPROVED
ADDRESS:	<input type="checkbox"/> APPROVED AS NOTED
ENGINEER:	<input type="checkbox"/> NOT APPROVED
SUBMITTAL DATA:	REMARKS:
NOTES 1:	
NOTES 2:	