

BALL VALVE - FULL PORT

MODEL LVBV (UL/FM)
AVAILABLE NO LEAD



FEATURES:

- Full-Port threaded ends (¼" to 2" with CSA/UL/NSF61/FM Approval)
- ¼" - 2" - UL/FM Approved to 600 PSI
- 2-piece forged brass
- Female NPT inlet and outlet
- 2½" to 4" - 400 WOG/CWP Optional; 150 SWP
- Valves conform to Federal Specifications WW-V-35, Type II Class A, Style 3 and MSS SP-110

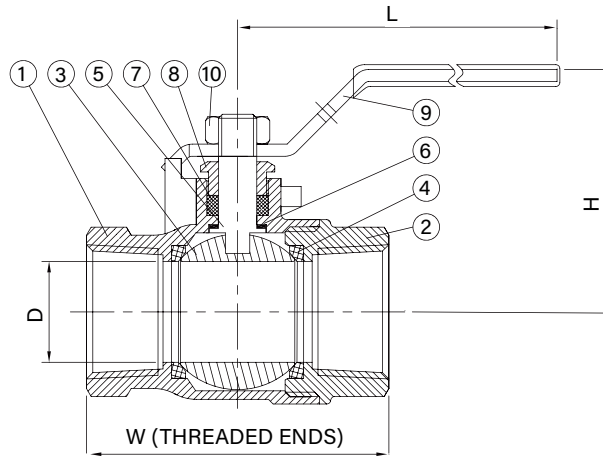

MATERIAL LIST		
NUMBER	DESCRIPTION	MATERIAL
1	Body	Forged Brass
2	End Cap	Forged Brass
3	Ball	Brass
4	Seat	PTFE
5	Stem	Brass (ASTM B16)
6	Thrust Washer	PTFE
7	Packing	PTFE
8	Gland	Brass
9	Handle	Carbon Steel Plated
10	Nut	Carbon Steel Plated

SIZE (In.)	D	W	H	L
1/4	.37	1.81	1.37	3.23
3/8	.37	1.81	1.37	3.23
1/2	.57	2.24	2.02	3.50
3/4	.75	2.48	2.40	4.10
1	.98	2.96	2.50	4.63
1-1/4	1.25	3.40	2.80	4.63
1-1/2	1.57	3.71	3.72	5.71
2"	1.97	4.25	4.00	5.71
2-1/2	2.50	5.35	4.52	9.13
3	3.0	6.32	4.96	9.13
4	3.74	7.17	5.57	9.13

PROJECT	APPROVAL STAMP
PROJECT:	
ADDRESS:	
ENGINEER:	
SUBMITTAL DATA:	REMARKS:
NOTES 1:	
NOTES 2:	