

BALL VALVE - FULL PORT

MODEL LVBV

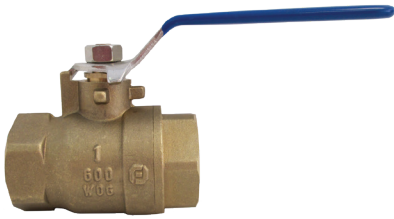

DESCRIPTION:

The Lansdale Model LVBV full port ball valve is UL Listed and FM Approved for use in fire protection piping trim, but can also be used in certain plumbing, HVAC, Waterworks, and industrial applications. Valves conform to Federal Specifications WW-V-35, Type II Class A, Style 3; MSS SP-110; ASTM B 584.

- Full-Port threaded ends
- CSA/UL/ANSI/CAN 61 & 372
- 2-piece forged brass
- Female NPT inlet and outlet
- 600 WOG/150 SWP

INSTALLATION:

This valve should be installed using standard industry practices, the male threads connecting to it should be coated with a Teflon thread sealant such as Lans Seal or a teflon tape prior to assembly.

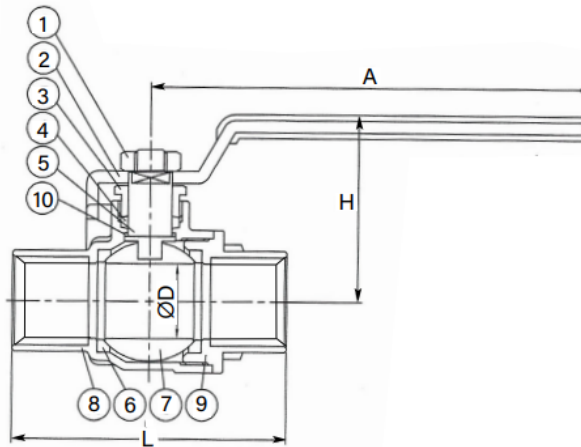

NOTE: *UL/FM APPROVED
** NOT UL/FM APPROVED

SIZE (in.)	L	H	D	A
*1/4	1.69	1.26	0.35	2.36
*3/8	1.81	1.46	0.39	3.15
*1/2	2.13	1.50	0.50	3.15
*3/4	2.48	1.85	0.75	4.33
*1	2.99	2.05	0.98	4.33
*1-1/4	3.35	2.36	1.26	5.12
*1-1/2	3.62	2.56	1.50	5.12
*2	4.25	3.11	1.97	7.87
**2-1/2	5.16	3.50	2.48	7.87
**3	5.91	3.86	2.95	7.87
**4	6.26	3.86	2.95	7.87

MATERIAL LIST		
NO.	DESCRIPTION	MATERIAL
1	Nut	AISI-1010
2	Handle	ASTM A283-D
3	Stem Gland Screw	ASTM B16-C36000
4	Stem Packing	Teflon PTFE
5	Stem	ASTM B16-C36000
6	Ball Disc Packing	Teflon PTFE
7	Ball Disc	ASTM B16-C36000
8	Body	ASTM B124-C37700
9	End Plug	ASTM B124-C37700
10	1 Thrust Washer	Teflon PTFE

PROJECT	APPROVAL STAMP
PROJECT:	<input type="checkbox"/> APPROVED
ADDRESS:	<input type="checkbox"/> APPROVED AS NOTED
ENGINEER:	<input type="checkbox"/> NOT APPROVED
SUBMITTAL DATA:	REMARKS:
NOTES 1:	
NOTES 2:	