

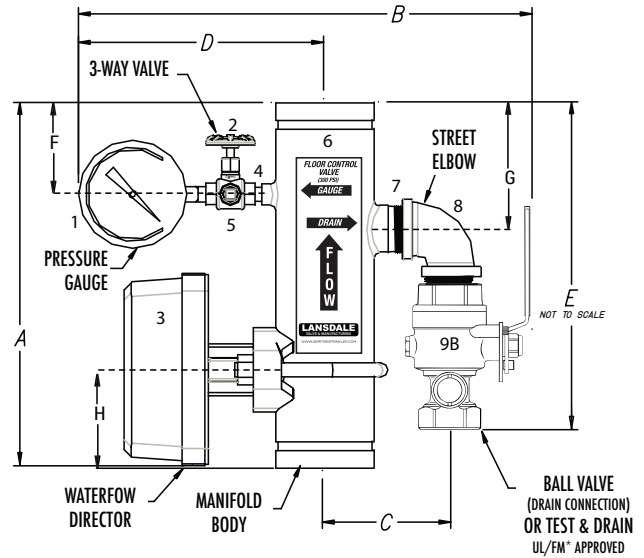

# COMMERCIAL RISER VALVE

LVCRBV - BALL VALVE SIZE  
LVCRTD - TEST & DRAIN

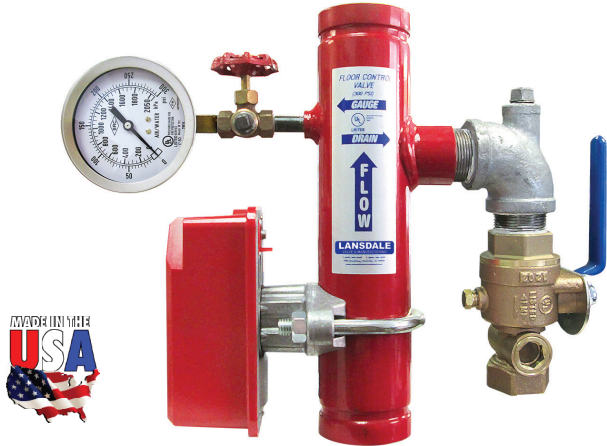

BODY SIZE	2"	2½"	3"	4"	5"	6"
<b>BALL VALVE SIZE</b> Model LVCRBV	1"	1¼"	1¼"	2"	2"	2"
<b>TEST &amp; DRAIN SIZE</b> Model LVCRTD	1"	1¼"	1¼"	2"	2"	2"

NOMINAL SIZE	2"	2.5"	3"	4"	5"	6"
<b>A</b>	13"	13"	13"	13"	13"	13"
<b>B (BALL VALVE)</b>	13"	13¾"	15 ¾"	19½"	20 5/8"	20"
<b>B (TEST &amp; DRAIN)</b>	13½"	14¼"	16¼"	19"	20 1/8"	20 ¾"
<b>C</b>	5¼"	5"	5½"	7"	7½"	8¼"
<b>D</b>	9¼"	9½"	9½"	10 3/8"	10 7/8"	11"
<b>E (BALL VALVE)</b>	5 5/8"	7 1/8"	9 7/8"	12 1/8"	13½"	13½"
<b>E (TEST &amp; DRAIN)</b>	10"	10¼"	12 ¼"	14¾"	14 ½"	14 ½"
<b>F</b>	3½"	3½"	3½"	3½"	3½"	3½"
<b>G</b>	4½"	4½"	4½"	4½"	4½"	4½"
<b>H</b>	3½"	3½"	3½"	3½"	3½"	3½"

NO.	DESCRIPTION	QTY.
1	Lansdale Air/Water 3½" Dia. 0-300 PSI with/stainless steel case UL/FM Approved	1
2	¼" 3-Way Valve	1
3	Water Flow Switch with retard UL/FM Approved	1
4	¼ x 2 Black Nipple	1
5	¼ Black CI Plug	1
6	Commercial Riser Body Sch 40 A53 steel pipe	1
7	Black Nipple_x close	1
8	Galvanized Street Elbow 90°	1
9A	Ball Valve 300 PSI, 600 WOG UL/FM Approved	1
9B	Lansdale Valve & Manufacturing or equal Test & Drain UL/FM Approved	1

**\*\*NOTE:** All tolerances (with exception of the grooves) plus or minus ¼ of an inch. All welds to be ¼" fillet surface prep of body-SSPC-SP-7 finished with 2.5 mils Bengal Red TGIC/Acrylic epoxy powder coat, electro statically applied.

**\*\*NOTE:** Standard Test & Drain orifice 5.6K, Optional orifice's available upon request: 4.2K, 14.0K, 25.2K

PROJECT	APPROVAL STAMP
PROJECT:	<input type="checkbox"/> APPROVED
ADDRESS:	<input type="checkbox"/> APPROVED AS NOTED
ENGINEER:	<input type="checkbox"/> NOT APPROVED
SUBMITTAL DATA:	REMARKS:
NOTES 1:	
NOTES 2:	