



OS&Y RESILIENT SEATED GATE VALVE with GROOVED ENDS

MODEL LV-OSYGG



DESCRIPTION:

The Lansdale NRS Resilient Seated Gate Valve with Grooved Ends, Model LV-OSYGG is used as a control valve for on/off applications.

- Valves comply with AWWA C515-15 standard
- OS&Y Resilient seated (EDPM encapsulated wedge)
- Triple O-Ring seal
- Available open right, please specify
- Grooved ends to AWWA C606
- 300 PSI working pressure
- NSF/ANSI/CAN 61 certified as lead-free for use in drinking water systems
- Fusion bonded epoxy coated interior and exterior to AWWA C550 standard

*Available with MJ and grooved connections including: FLxFL; GxG; GxFL

INSTALLATION:

Refer to Lansdales' O&M manual for further information and installation instructions.

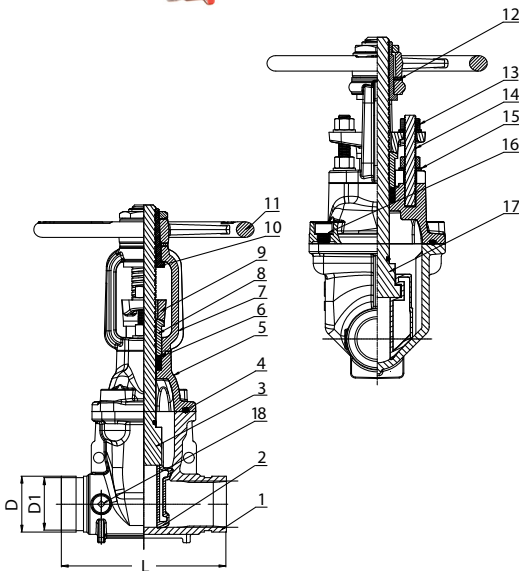

DIMENSIONS (in.)			
SIZE (in.)	L	D	D1
2	7.00	2.37	2.25
2-1/2	7.40	2.87	2.72
3	8.00	3.50	3.34
4	9.00	4.50	4.33
6	10.50	6.63	6.46
8	11.50	8.63	8.44
10	13.00	10.75	10.56
12	14.00	12.75	12.53

MATERIAL SPECIFICATIONS			
PART NO.	PART NAME	MATERIAL	ASTM SPEC.
1	Valve Body	Ductile Iron	A536 65-45-12
2	Resilient Wedge Disc	DI & EPDM	A536 65-45-12
3	Stem	Stainless Steel	TY304
4	Bonnet Gasket	EPDM	—
5	Bonnet	Ductile Iron	A536 65-45-12
6	Stem Packing	EPDM	—
7	Yoke	Ductile Iron	A536 65-45-12
8	Stem Bushing	Brass	B62/C83600
9	Gland	Ductile Iron	A536 65-45-12
10	Wedge Nut	Brass	B62/C83600
11	Handwheel	Ductile Iron	A536 65-45-12
12	Nut	Stainless Steel	TY304
13	Washer	Brass	B62/C83600
14	Gland Nut	Stainless Steel	TY304
15	Stud	Stainless Steel	TY304
16	Flat Washer	Stainless Steel	TY304
17	Bolt	Stainless Steel	TY304
18	O-Ring	NBR	—
19	Plug	Brass	B62/C83600

PROJECT	APPROVAL STAMP
PROJECT:	<input type="checkbox"/> APPROVED
ADDRESS:	<input type="checkbox"/> APPROVED AS NOTED
ENGINEER:	<input type="checkbox"/> NOT APPROVED
SUBMITTAL DATA:	REMARKS:
NOTES 1:	
NOTES 2:	