

SWING CHECK VALVE WITH LEVER & WEIGHT

MODEL LVLWCV



DESCRIPTION:

Swing Check Valves are used to prevent the back-flow of water within a piping system. They come with and without an outside Lever and Weight which conforms to AWWA C508. In order for a check valve to properly function there should be a differential pressure of at least ½ PSI, this will prevent water hammer and chatter.

FEATURES:

- Resilient seated (EPDM rubber face on the ductile iron disc)
- Bronze seat ring
- "Full Waterway" design per AWWA C508 Standard
- Fusion bonded epoxy powder coated - certified to NSF/ANSI-61 for use in drinking water systems
- Fusion bonded epoxy coated Interior and exterior per AWWA C550 Standard
- Working pressure rated at 200 PSI
- Flanged ends to ANSI B16.1, Class 125
- Temperature range: 33° F to 170° F
- May be installed vertically or horizontally for vertical installations, flow must be in upward direction

INSTALLATION:

Upon receipt of the valves, inspect them for conformance to what was ordered, and any damage that may have occurred during shipment. Carefully inspect the valve disc and seating area for any damage and be careful not to have them come into contact with any tools during the installation process. This installation must be performed by experienced contractors, and in accordance with any local requirements as well as AWWA specifications including AWWA M-11, which requires proper support of the valve and associated piping.

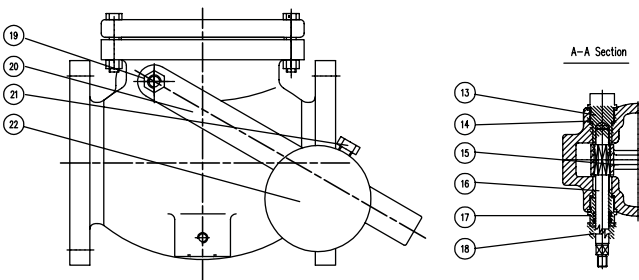
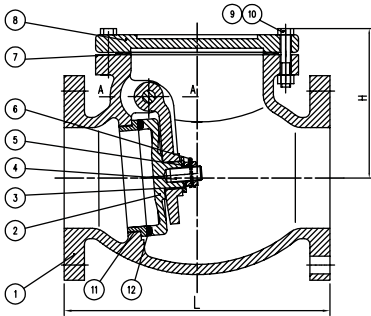

NO.	DESCRIPTION	MATERIAL
1	Body	Cast Iron, A126 Class B
2	Body Trim	Bronze, B62 C83600
3	Disc Trim	Rubber, EPDM
4	Disc	Cast Iron, A126 Class B
5	Hanger	Ductile Iron, A536, 65-42-12
6	Bonnet	Cast Iron, A126 Class B
7	Disc Spacer	Carbon Steel
8	Hanger Bolt	Stainless Steel, SS304
9	Hanger Nut	Stainless Steel, SS304
10	Cotter Pin	Stainless Steel, SS304
11	Plug	Brass
12	Spacer	PTFE
13	Bushing	Brass
14	Bushing	Brass
15	O-Ring	Rubber, EPDM
16	Stem	Stainless Steel, SS304
17	Stem Nut	Carbon Steel
18	Bolt	Carbon Steel
19	Gasket	Graphite
20	Lever	Carbon Steel
21	Bolt	Carbon Steel
22	Weight	ASTM A126 Class B

DIMENSIONS (In.)									
SIZE	2	2.5	3	4	5	6	8	10	12
L	8	8.5	9.5	11.5	13	14	19.5	24.5	27.52
H	4.8	5.3	5.55	6.6	7.17	8.46	10.5	12	13.5

PROJECT	APPROVAL STAMP
PROJECT:	<input type="checkbox"/> APPROVED
ADDRESS:	<input type="checkbox"/> APPROVED AS NOTED
ENGINEER:	<input type="checkbox"/> NOT APPROVED
SUBMITTAL DATA:	REMARKS:
NOTES 1:	
NOTES 2:	



SWING CHECK VALVE SPRING KIT

MODEL LVCVSPK



DESCRIPTION:

The Lansdale, “Swing Check Valve-Spring Kit” can easily be attached to our standard 3”-12” Lever and Weight Check Valve. The kit consists of a properly sized spring and a shaft that can be attached to the valve in predrilled holes and tappings. . The swing check with lever and spring is suitable for high pressure piping, with insufficient back pressure and high velocities of fluid traveling through the piping. The spring tension ensures that the clapper will close quickly and gently thereby preventing water-hammer, which can be extremely destructive to the piping system. Both the spring post and spring are made of stainless steel insuring a high degree of corrosion resistance.

MATERIAL SPECIFICATIONS		
PART NO.	MATERIAL	ASTM SPECIFICATION
Spring	Stainless Steel	A276 Grade 304
Spring Post	Stainless Steel	A276 Type 420

PROJECT	APPROVAL STAMP
PROJECT:	<input type="checkbox"/> APPROVED
ADDRESS:	<input type="checkbox"/> APPROVED AS NOTED
ENGINEER:	<input type="checkbox"/> NOT APPROVED
SUBMITTAL DATA:	REMARKS:
NOTES 1:	
NOTES 2:	