

TEST & DRAIN PRV KIT

MODEL LVTDPR



FEATURES:

- Tamper Resistant 5.6k test orifice & sight glass
- Field adjustable 175 - 310 psi pressure relief valve
- Pre-assembled for field installation saving time & money!
- Available in 1", 1-1/4", 1-1/2", 2"
- 300 PSI rated Lansdale UL/FM Approved Test & Drain

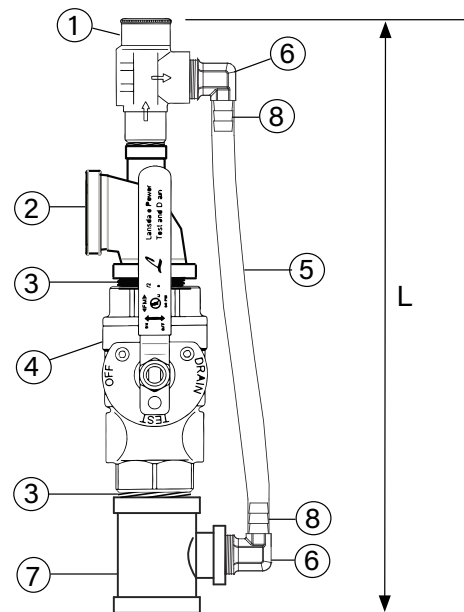

MATERIAL LIST	
ITEM	DESCRIPTION
1	1/2" x 175-310 PSI Pressure Relief Valve
2	S x S x 1/2" Galv. MI Tee
3	S x CL Galv. Nipple
4	Lansdale Test & Drain
5	3/8" Reinforced PVC Tubing
6	1/2" X 3/8" 90° Brass Elbow
7	S x 1/2" X S Galv. MITee
8	3/8" Hose Clamp

DIMENSIONS	
SIZE (IN)	L (IN)
1"	10 7/8
1 1/4"	11 1/8
1 1/2"	11 5/8
2"	11 5/8

*Note: S stands for size of Test & Drain

PROJECT	APPROVAL STAMP
PROJECT:	<input type="checkbox"/> APPROVED
ADDRESS:	<input type="checkbox"/> APPROVED AS NOTED
ENGINEER:	<input type="checkbox"/> NOT APPROVED
SUBMITTAL DATA:	REMARKS:
NOTES 1:	
NOTES 2:	