

WATER METER COUPLING

MODEL LVWMC



FEATURES:

- Lead Free Brass*
- With Gasket
- AB 1953 Compliant
- Sizes 3/4" - 2"

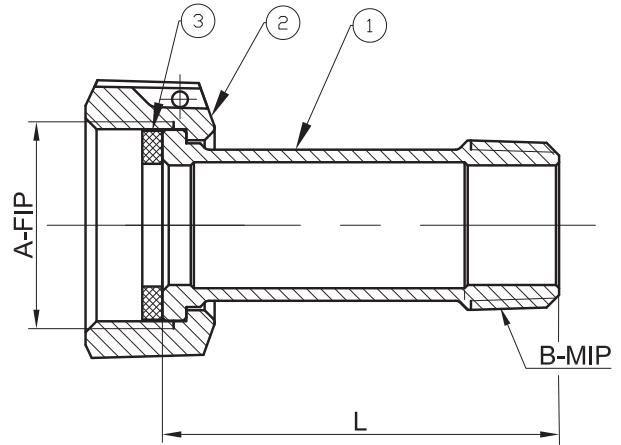

Dimensions		
Part #	Size	L
200-225-00220	3/4" MIP X 1" FIP	2.48
200-225-00240	1" MIP X 1 1/4" FIP	2.62
200-225-00340	1 1/2" MIP X 2" FIP	2.83
200-225-00360	2" MIP X 2 1/2" FIP	3.01

No.	Part	Material
1	Nut	Brass C46500
2	Packing	EPDM
3	Nipple	Brass C46500
4	Cover	Plastic

*This product complies with 0.25% weighted average lead content on wetted surfaces in accordance with the Safe Drinking Water Act (SDWA) / Federal Public Law No. 111-380.

PROJECT	APPROVAL STAMP
PROJECT:	<input type="checkbox"/> APPROVED
ADDRESS:	<input type="checkbox"/> APPROVED AS NOTED
ENGINEER:	<input type="checkbox"/> NOT APPROVED
SUBMITTAL DATA:	REMARKS:
NOTES 1:	
NOTES 2:	