

LANSDALE

VALVE & MANUFACTURING

1040 Broadway Westville, NJ 08093 / Phone: (800) 908-0523 / Fax: (856) 456-9223 / www.gemfiresprinkler.com

STEEL F&C PLATE

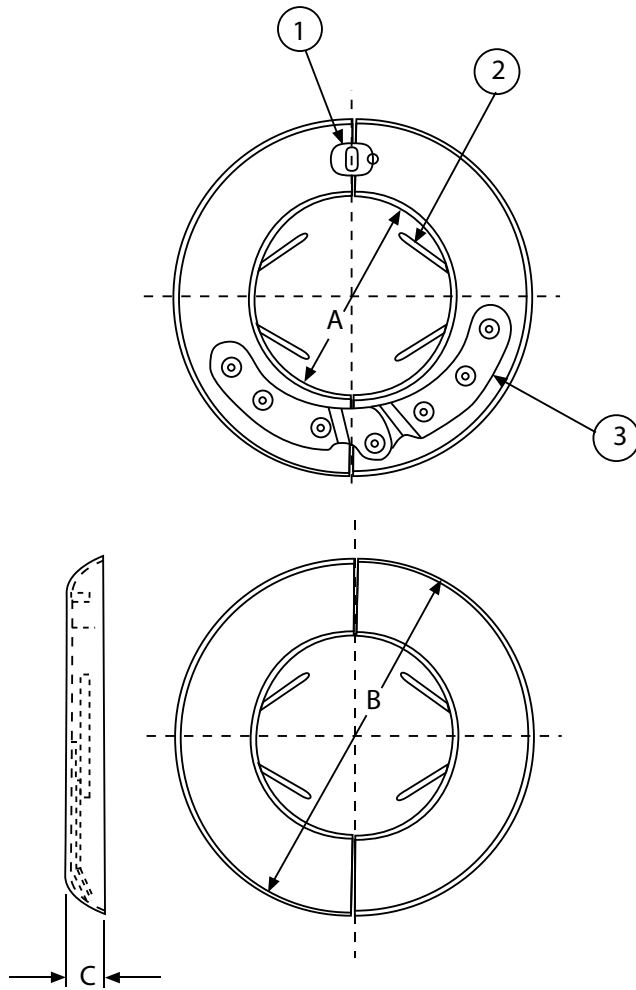

- 1. Buckle: Cast Brass
- 2. Spring: Brass
- 3. Hinges: Brass

Size	A	B	C
.5"	.88"	2.63"	.33"
.75"	1.135"	2.842"	.32"
1"	1.417"	3.299"	.346"
1.25"	1.771"	3.58"	.362"
1.5"	2.077"	3.86"	.315"
2"	2.47"	4.5"	.342"
2.5"	2.992"	5.22"	.33"
3"	3.6"	5.9"	.362"
4"	4.645"	7.086"	.362"
5"	5.9"	8.976"	.39"
6"	6.889"	9.842"	.417"
8"	8.858"	13.188"	.393"

PROJECT	APPROVAL STAMP
PROJECT:	<input type="checkbox"/> APPROVED
ADDRESS:	<input type="checkbox"/> APPROVED AS NOTED
ENGINEER:	<input type="checkbox"/> NOT APPROVED
SUBMITTAL DATA:	REMARKS:
NOTES 1:	
NOTES 2:	